

# Installation instruction EQUUS\_39-49 with cable

0. The installation should be carried out by qualified personnel only.
1. Ensure Voltage and Frequency match values shown through rear window(A).
2. Mount EQUUS either by stainless steel screw (M10, ST9.5), strap, ground spike or with SPEKTOR\_Mounting\_Adaptor (accessory, see rear page).
3. Disconnect mains power before terminating wires of cable (B): brown=phase, blue = neutral, yellow/green = earth. Seal electrical connection as needed, ideally with an IP68 connector.

Ta = 40, IP66

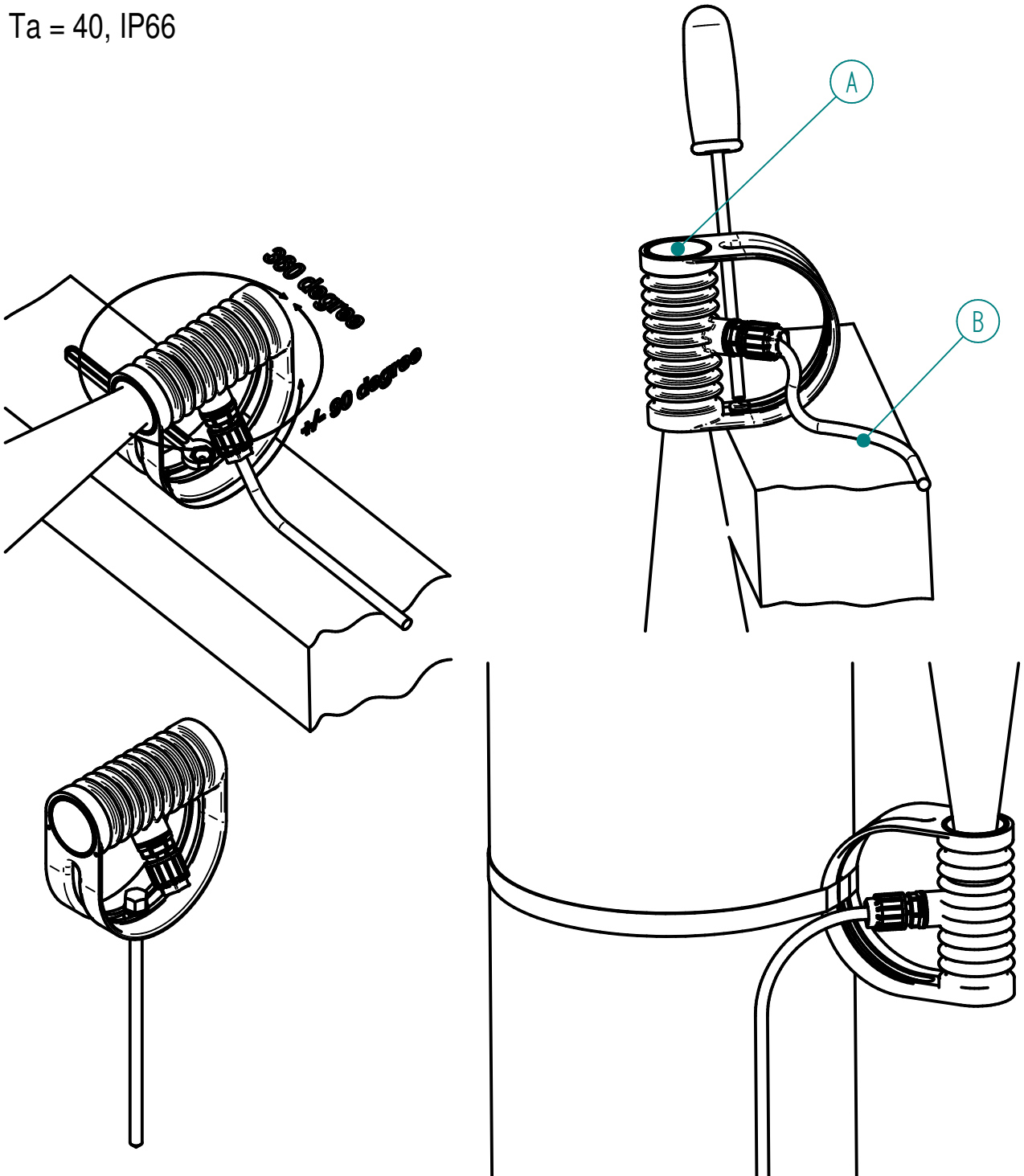

# SPEKTOR\_Mounting\_Adaptor (accessory)

on flat walls or corners with 2 crews ST4.8 (A) 50mm apart:

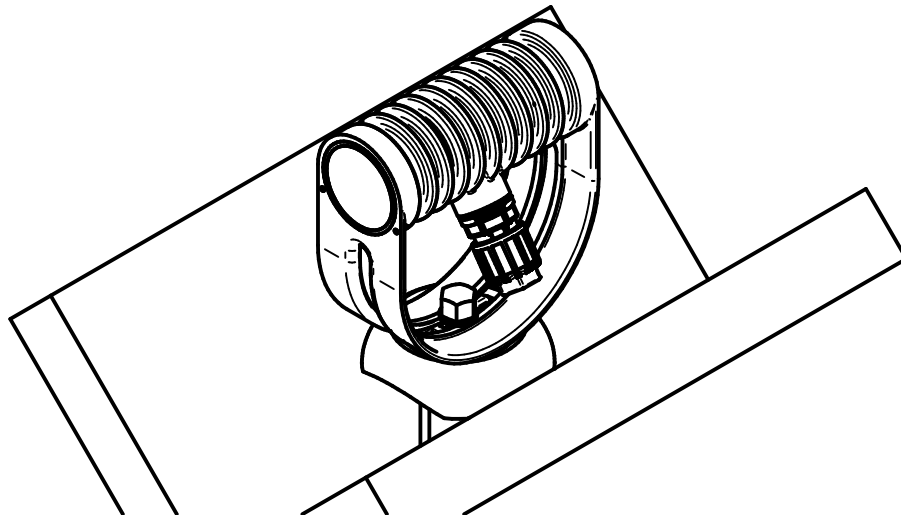
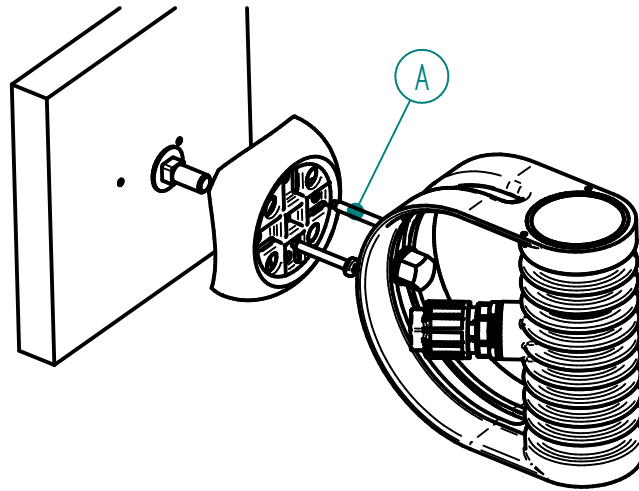

or with metal straps on poles with diameter 102mm, 114mm or larger:

